



**DLA**  
DEFENSE LOGISTICS AGENCY  
*Established 1961*



The Nation's Combat Logistics Support Agency

# DLA Clothing & Textiles Special Purpose & Chemical Clothing

Thomas Darcy, IST  
Supervisor/Contracting Officer  
Nov 17, 2022



WARFIGHTER ALWAYS



# TEAM POCs

Name	Title	Phone	E-Mail
Thomas Darcy	IST Supervisor/Contracting Officer	215-737-3068	<a href="mailto:Thomas.Darcy@dla.mil">Thomas.Darcy@dla.mil</a>
Don Howarth	Acq Specialist/Contracting Officer	215-737-0429	<a href="mailto:Donald.Howarth@dla.mil">Donald.Howarth@dla.mil</a>
Isaiah Muray	Acq Specialist/Contracting Officer	215-737-5817	<a href="mailto:Isaiah.Murray@dla.mil">Isaiah.Murray@dla.mil</a>
John Green	Acq Specialist	215-737-3169	<a href="mailto:John.e2.Green@dla.mil">John.e2.Green@dla.mil</a>
Tiffany Savage	Acq Specialist	See E-Mail	<a href="mailto:Tiffany.Savage@dla.mil">Tiffany.Savage@dla.mil</a>
Shane Moore	Acq Specialist	See E-Mail	<a href="mailto:Shane.Moore@dla.mil">Shane.Moore@dla.mil</a>



# Special Purpose Clothing

- Jackets
  - Flyers 36/P & 45P (Sage & Tan)
  - Leather A-2 & G-1 (USAF & USN)
  - Leather, Surface Warfare Officer (USN)
  - Cold Weather Shipboard Jacket
- Multi-Climate Protection System (MCPS)
  - Shirts/Drawers (Silk-Wt, Mid-Wt, Heavy-Wt)
  - Overalls, Vest, Jacket Liners



# Special Purpose Clothing

- Army Aircrew Combat Uniform (A2CU)
- Otto Fuel Protective Items
- Wildland Firefighting Shirt, Trousers
- Flight Deck Jerseys/ Flight Deck Trousers (New)
- Anti-Flash Hood
- Neck Gaiter
- Advanced Combat Shirt and Advanced Combat Pant



# Special Purpose Clothing

- Flyers – 27/P (Sage & Tan)
- Improved Combat Vehicle Crewmen (ICVC)
- Utility – Green Shipboard / Blue Coverall
- Navy IFRV Coveralls
- Fuel Handlers Coveralls
- Mechanics Coveralls
- Coverall with Hood & Booties
- Disposable Coverall
- Personal Protective Equipment (Various Items)



# Special Purpose Obligations

- Material Obligations
  - FY 20 Actual - \$143.7 Million
  - FY 21 Actual - \$191.9 Million
  - FY 22 Actual - \$103.4 Million
  
- SALES (@ Standard)
  - FY 20 - \$217.2 Million
  - FY 21 to date - \$678.1 Million (Majority for COVID PPE)
  - FY 22 - \$140.8 Million



# Chemical Protective Clothing Product Line Overview

- Overboots, Molded, Lightweight, Chemical/Biological Protective (MALO)
- Gloves – Butyl, JB2GU, Glove Inserts
- Toxicological Agent Protective Items (TAP)
- Joint Service Lightweight Integrated Suit Technology (JSLIST)
- Joint Protective Aircrew Ensemble (JPACE), Lightweight Joint Protective Air Crew Ensemble (LJPACE) Male & Female and Repair Kits
- Chemical Protective Helmet Covers
- Carrying Bag (for JSLIST)





# Chem Product Line Overview

- Items currently procured are for Warfighters only.
- Items subject to International Traffic in Arms Regulations (ITAR).
- DLA two major customers:
  - Individual Chemical Equipment Management Program (ICEMP). Office provides centralized management and funding of U.S. Army chemical individual protective equipment.
  - Military Service War Reserve Stocks.





# Chemical Obligations/Sales

- Material Obligations –
  - FY 20 Actual - \$33 Million
  - FY 21 Actual - \$33.8 Million
  - FY 22 Actual – \$42.4 Million
  
- SALES (@ Standard) –
  - FY 20 - \$122.6 Million
  - FY 21 - \$46.8 Million
  - FY 22 - \$83.8 Million



# PRODUCT DEMONSTRATION MODELS (PDMs)

- Product Demonstration Models
  - Product Demonstration Models (PDMs) are required to be submitted through traceable means via the U.S. Postal Service or a Commercial Carrier (Example: FedEx, Airborne, UPS, DHL, Emery). Due to COVID-19, in-person delivery of PDMs by offerors is not authorized. The Tracking Number shall be provided as part of the DIBBS electronic upload proposal submission.
  - PDMs are to be delivered between 8:00 a.m. and 1:00 p.m. E.S.T., Monday through Friday, except for legal federal holidays as set forth in 5 USC 6103. Packages must be plainly marked **ON THE OUTSIDE OF THE CARRIER'S PACKAGE** with the solicitation number, date, and time set forth for receipt of offers as indicated in block 9 of the Standard Form 33. Ultimately, it is the offeror's responsibility to ensure that its PDMs are received at the correct location at the correct time. Failure to do so may result in the offeror's proposal being deemed untimely and not considered further for the award per FAR 52.215-1 Instruction to Offerors - Competitive Acquisitions.



# PRODUCT DEMONSTRATION MODELS (PDMs)

- All PDMs shall be sent to the following address:

DLA Troop Support  
ATT: BUYERS NAME  
Building 3-A-4422  
700 Robbins Avenue  
Philadelphia, PA 19111

- Effective 01 October 2021, all carriers/individuals attempting to deliver any packages/proposals/PDMs/First Articles/etc. to DLA Troop Support shall have present credentials that meet Real ID requirements in order to gain access to make a delivery. **NO EXCEPTIONS SHALL BE MADE.**



## Upcoming Opportunities

- Future solicitations currently being planned. Look at [beta.SAM.gov](https://beta.sam.gov) for future details and Market Research Surveys that will help in the development of our Acquisition Strategies.
1. JB2GU – Solicitation 12/22
  2. MALO – Solicitation 1/23
  3. LJPACE/JPACE – TAD 4/23
  4. Shipboard Jacket – TAD 12/22
  5. Coverall, Shipboard, Green - TAD 4/23
  6. Coverall, Shipboard, Blue - TAD 6/23
  7. Flight Deck Jersey – Solicitation 12/22
  8. ACS – Solicitation 1/23
  9. 27P Coverall – Solicitation Spring 2023



**DLA**  
DEFENSE LOGISTICS AGENCY  
*Established 1961*



The Nation's Combat Logistics Support Agency

# DLA Clothing & Textiles Flight / Safety

Jennifer Scarpello  
IST Chief  
Safety Gear Team  
November 17, 2022



WARFIGHTER ALWAYS



# Product Line Overview

- Safety Team Stats

- Overall manage approx. 900 different items

- Items include:

- Flyers Helmets and components (Visors, Chin Straps, ...)
    - Anti-G Garments
    - Anti-Exposure Garments
    - Ballistic Helmets and components (Retention Systems, Pad (Suspension) Systems, Covers)

- Sales

- FY 22 - \$66.2M
    - FY 21 - \$67.7M
    - FY 20 - \$82.0M
    - FY 19 - \$79.0M







## Upcoming Opportunities

- Airsave Vest & Accessories - Small Business Set-Aside (Vest, panels, pocket, mount) Fixed Quantity – Solicitation Issue December 2022
- Flight Deck Helmet – Small Business Set-Aside 5-year Tier Indefinite Delivery, Indefinite Quantity (IDIQ) – Solicitation Issue December 2022
- Advanced Technology Anti-G Suit 22/P – Full & Open 4-year Tier Indefinite Delivery, Indefinite Quantity (IDIQ) – Solicitation Issue January 2023





## Upcoming Opportunities

- Air Solider System (AIR SS) Primary Survival Gear Carrier (PSGC) Vest – Full & Open – Fixed Quantity (1,200 units) – Solicitation Issue 1Q2023
- Socks, Flyers Anti 86P / 87P – Full & Open - Solicitation Issue 2Q2023
- Crew Restraint Tether Assembly (CRTA) – Full & Open - Solicitation Issue 3Q2023



# Safety Team Points of Contact

- Michael Medora: Division Chief
  - [michael.medora@dla.mil](mailto:michael.medora@dla.mil)
  - 215-737-3274
- Jennifer Scarpello: IST Supervisor
  - [Jennifer.scarpello@dla.mil](mailto:Jennifer.scarpello@dla.mil)
  - 215-737-3164
- Dan Price: Contracting Officer
  - [daniel.price@dla.mil](mailto:daniel.price@dla.mil)
  - 215-737-8101
- Contract Specialists:
  - Mara Cremen: [mara.cremen@dla.mil](mailto:mara.cremen@dla.mil) 215-737-8094
  - Lisa Pizzo: [lisa.pizzo@dla.mil](mailto:lisa.pizzo@dla.mil) 215-737-8076
  - Bob Rounay: [robert.rounay@dla.mil](mailto:robert.rounay@dla.mil) 215-737-7123
  - Ed Klos: [edward.klos@dla.mil](mailto:edward.klos@dla.mil) 215-737-8105
  - David Falkowski: [david.falkowski@dla.mil](mailto:david.falkowski@dla.mil) 215-737-5395
  - Rabah Yisrael: [rabahben.yisrael@dla.mil](mailto:rabahben.yisrael@dla.mil) 215-737-0636



? ? ?  
? ? ?  
*Questions*  
? ? ?



# **AF Uniform Office Flight Duty Uniform Programs**

**JAPBI Nov 2022**

**Stephanie Weatherhead**  
Air Force Uniform Office  
Clothing Designer  
[stephanie.weatherhead@us.af.mil](mailto:stephanie.weatherhead@us.af.mil)



# Maternity Overview



*AFLCMC... Providing the Warfighter's Edge*

## MATERNITY DEVELOPMENT OVERVIEW

- To provide maternity flight suits for all pregnant aircrew across the AF & Sister Services
- Address issues with safety, comfort, & improved performance for pregnant aircrew through pregnancy & post-pregnancy (total of 18 months) allowing them to maintain current flight status & accomplish mission
- Create a Government owned solution

### PHASE I

#### INTERIM SOLUTION

- No current solution available
- Modify the current 27/P for maternity fit until permanent solution is available
- Limitations of modifying existing uniform

**COMPLETE**

### PHASE II

#### 1 PC PERMANENT SOLUTION

- Development of the one-piece MFDU
- Multi-Service Common Solution

### PHASE III

#### 2 PC PERMANENT SOLUTION

- Development of a two-piece version of A2CU/A2CU-F
- Multi-Service Common Solution
- Requires fabric development
- Design modifications required to pass burn testing





# Female Manikin Development



*AFLCMC... Providing the Warfighter's Edge*

## First Female Pyro Burn Manikin

Completed December 2020



**Female Styrofoam  
Prototype**



**Dressed Styrofoam  
Prototype**



**Sensor  
Placement**

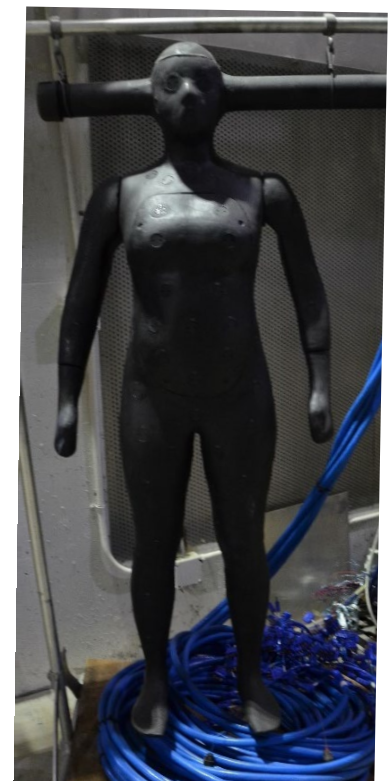

**Final Female  
Pyro-Manikin**



# Franny “The Female Manikin”



*AFLCMC... Providing the Warfighter's Edge*

**Franny was designed with a removable front pregnancy panel, reflecting the core maternity specs of the bust & belly**

Note: Burn testing is not pass or fail, but based on survivability, which is further analyzed by the Engineering Team for Safe-to-Fly & Air Worthiness Approvals.



**Female Pyro**



**Maternity Pyro**



**Female Pyro**



**Maternity Pyro**





# MFDU Design

*AFLCMC... Providing the Warfighter's Edge*



## MFDU DESIGN

### Phase II

- **Utilized fabric & design from current 27/P (Nomex®/Kevlar®/P-140 blend)**
  - Known testing and performance results
  - Creates consistency in field
- **Sizing was converted to alpha to address low demand**
- **Updated design & fit through bodice, belly, & hips to accommodate the maternity form**
- **Waist tabs allow for adjustability to accommodate multiple stages of pregnancy**





# MFDU Illustrations

AFLCMC... Providing the Warfighter's Edge



## Maternity Flight Suit – New Design

New Design & proto approved 15 July 2020

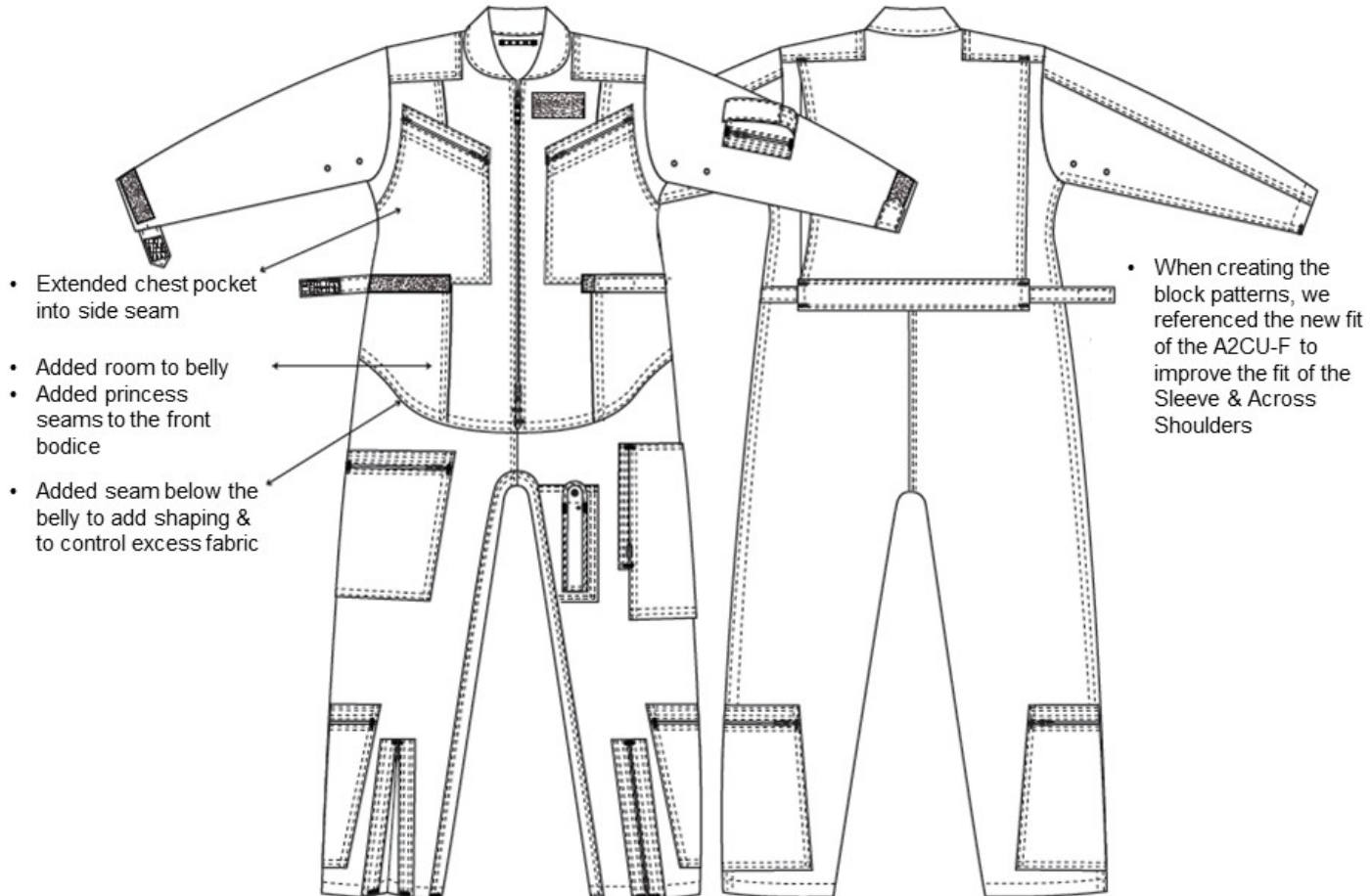



# Maternity A2CU Design

AFLCMC... Providing the Warfighter's Edge



## OVERALL DESIGN

### Phase III

- **Utilized fabric & design from current A2CU/A2CU-F**
  - Known testing & performance results
  - Creates consistency in field
- **Designed to accommodate room in belly & hips without creating a large overall appearance**
- **Safe-to-Fly Flash Flame requirements**
  - Cinch bottom hem with bungee cord & barrel lock to avoid chimney effect
  - Tuck extra cording into interior hook & loop pocket to avoid snag hazard

## COAT DESIGN

- Princess seaming for shape
- Longer length for growth
- Bungee cord with barrel lock at bottom hem for safety
- All pockets as per A2CU-F except for Microclimate Cooling Garment (MCG) opening, which was removed due to garment real estate

## TROUSER DESIGN

- Trousers contain FR stretch belly panel with elastic waistband, which accommodates all stages of pregnancy
- All pockets remain as per A2CU-F except for the side hanging hip pocket closure (A2CU-F has two pieces of hook/loop closure, whereas the Maternity A2CU has one)





# Maternity A2CU Design Cont.

AFLCMC... Providing the Warfighter's Edge



## Final House Proto of Maternity A2CU



**FRONT**

**SIDE**

**BACK**



**BELLY PANEL  
FRONT**



**BELLY PANEL  
SIDE**



**BELLY PANEL  
BACK**



# Maternity A2CU Coat

## Illustrations

AFLCMC... Providing the Warfighter's Edge



**FRONT**

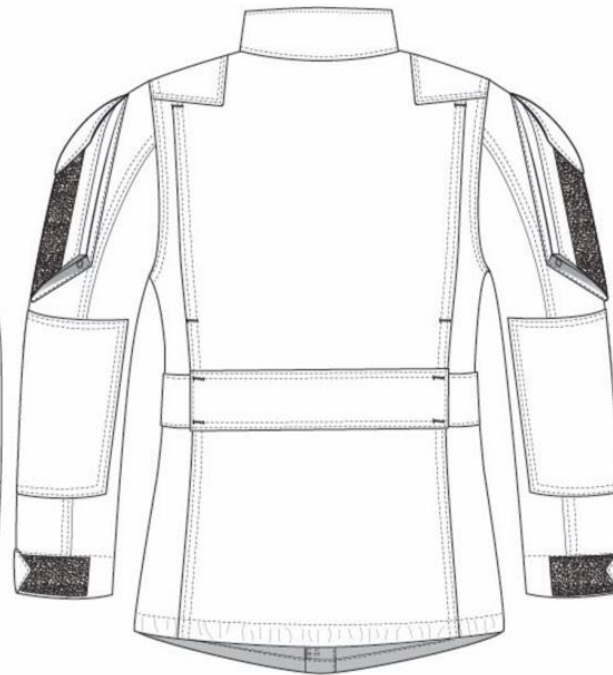

**BACK**

### COAT HEM DETAILS

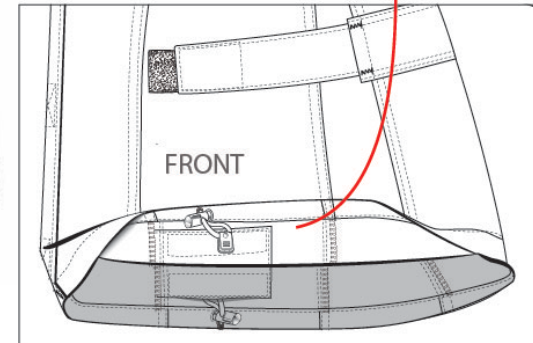
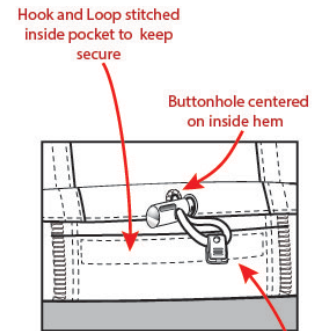



# Maternity A2CU Trouser Illustrations

AFLCMC... Providing the Warfighter's Edge

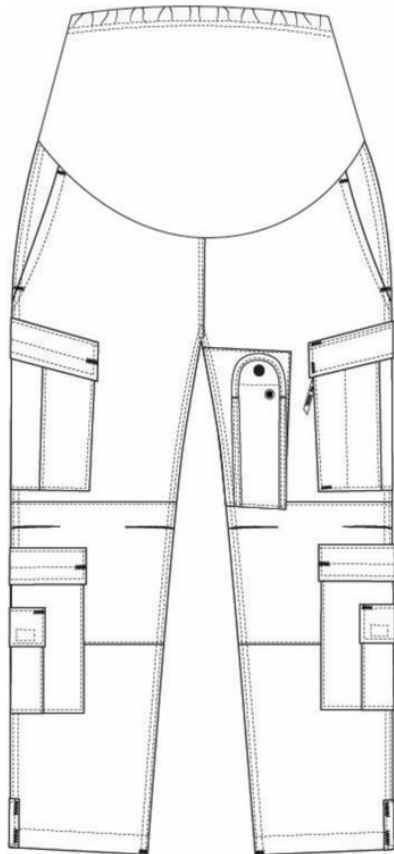

**FRONT**

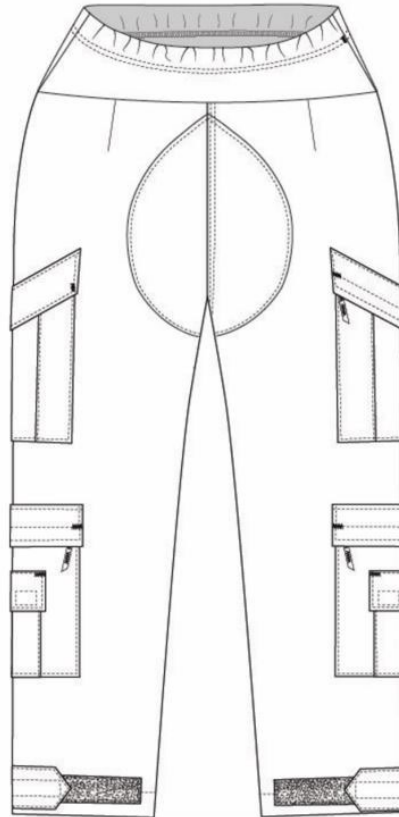

**BACK**

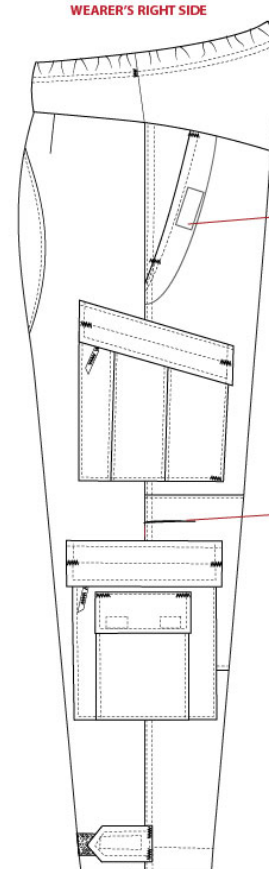

**WEARER'S RIGHT SIDE**

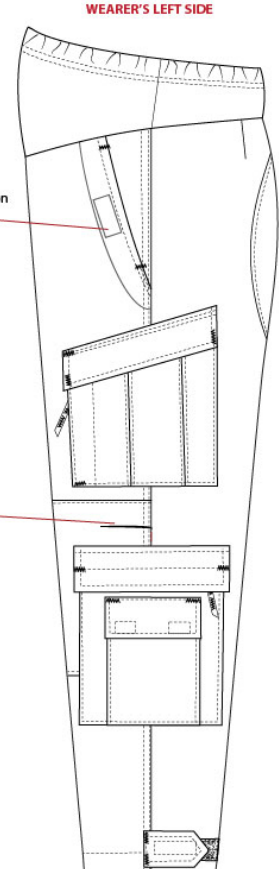

**WEARER'S LEFT SIDE**

Hook and loop are on the inside of the pocket.

Pleat

**SIDE**



# Way Forward

*AFLCMC... Providing the Warfighter's Edge*



## Design & Development

- **New Maternity Uniforms**
  - **Space Force**
- **Maternity Continuous Product Improvements**
  - **Service Dress: Skirt**
  - **Mess Dress: Slacks**
  - **Maternity Ensemble: Dress, Skirt, Coat, Slacks**





# Questions?

*AFLCMC... Providing the Warfighter's Edge*





# **AF Uniform Office**

## **Heated Flight Suit**

### **Uniform Programs**

**JAPBI Nov 2022**

**Mr. Donald R. Lee**

Program Manager/ Clothing & Textiles Domain Lead

COMM: 508-206-3071

Donald.lee.12@us.af.mil



# AF Heated Flight Clothing (HFC)



AFLCMC... Providing the Warfighter's Edge

## Background:

- Need heated flight clothing items to protect aviators in extreme cold weather – requirements for rotary and ejection seat aircrew
- Ejection platforms have battery size limitations

## What We've Done:

- RFI submitted for HFC items in 2018 & 2019
- Ground evals performed on available items for rotary aircrew Feb 2022
- Supported ongoing SBIR II efforts for heated gloves and heated boot inserts

## Plan Forward:

- Seek and evaluate additional HFC items



Rotary aircrew have missions flown with doors open in winter



Ejection pilots need hand and foot protection during parachute descent if ejection occurs in extreme cold

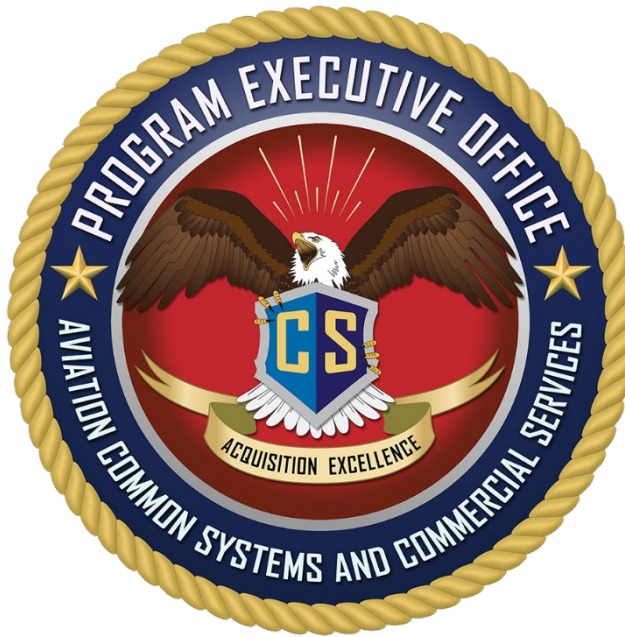

# Naval Air Systems Command



*Presented to:*

**Joint Advance Planning Briefing to Industry**

17 November, 2022







# PMA202: Aircrew Systems



## Personal Protection & Performance

- **Anti-exposure systems**
- Boots, gloves, socks, undergarments
- Communication headset components
- Flight Clothing: suits & jackets
- **Flight Deck & Maintainer Cranials**
- **Helmets, Hearing Protection systems**
- Personal heating & cooling systems

## Combat Survivability & Perseverance

- Anti-G-Force protection suits
- Bladder Relief systems
- **Body Armor**
- High endurance seat cushions
- Hydration sustainment systems
- **Laser Eye Protection & FOD glasses**
- **Smoke masks**

## Physiological Episode Protection

- **Oxygen generation systems, masks, filters, monitors, emergency bottles**

## Visual Situational Awareness

- Enhanced Visual Acuity (EVA)
- Night Vision Cueing & Display (NVCD)
- Night Vision Goggles

## Chem Bio Defense: Protection & Perseverance

- **Detection & Decontamination systems**
- **Respirators**
- **Skin exposure protection clothing**

## Escape, Egress, Evasion & Recovery

- **Crashworthy seats & Restraint systems**
- **Escape systems – ejection seats**
- **Parachutes**
- **Survival radios, signaling devices**
- **Survival rafts, Life Preservers**
- **Survival vests, Survival kit items**
- **Underwater breathing apparatus**

**1100 In-Service Products, 13 active acquisition initiatives**



**Deliver aircrew and aviation maintainer systems in order to optimize Naval aviation's combat effectiveness**



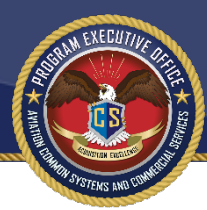

# Flight Clothing



- General Purpose Safety and Flight Deck Boot
  - Boot to be issued during training as standard boot
  - Aircrew using brown boot
- Preparing minor changes to 2 piece flight suit (A2CU) for Navy version in sage green
- Planning to become a user of USAF maternity flight suit
- USAF CWAS Jacket now being issued by Navy Training in place of the CWU-32/P Summer Flyer's Jacket
- Evaluating cold weather outer garment needs
- Certification of leather suppliers for G-1 Leather Flyer's Jacket





# Design for Maintainer Program



- Helmets
- Hearing protection
- Organizational clothing
  - Flight deck jerseys and trousers
  - Coveralls
  - Boots
  - Gloves
  - Cold weather clothing
  - Foul weather clothing





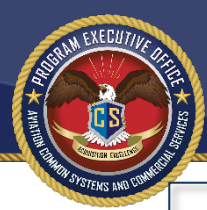

# Helmet and Hearing Protection Products



## Helmet

- Team Wendy Exfil LTP



# HGU-98/P

## Hearing protection

### NON Communication

- 3M Peltor x4 hearing protection – non comm ear cups
- 3M Peltor x5 hearing protection - non comm ear cups

### Communication

**In test and  
assessment phase**

- Invisio T7 – comms headset
- Invisio X5 – in ear comms set
- 3M Peltor ComTac V



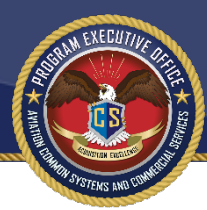

# Maintainer Clothing Efforts



- Marine Corps OD Green FR Coveralls
- Marine Corps OD Green FR Flight Deck Jersey and Trousers
  - limited user evaluation found acceptable
  - adding color to existing technical data package
- Cold Weather Jacket: COTS solutions identified
- Navy FR 2 piece Maintainer Ensemble: potential replacement for flight deck trouser
- Evaluation of I2FRV developed by NAVSUP
- Improved gloves for maintainers: evaluated government and commercial solutions





# Questions

